

SN74GTL2014 4-Channel LVTTTL to GTL Transceiver

1 Features

- Operates as a GTL–/GTL/GTL+ to LVTTTL or LVTTTL to GTL–/GTL/GTL+ Translator
- The LVTTTL Inputs are Tolerant up to 5.5 V Allowing Direct Access to TTL or 5 V CMOS
- The GTL Input/Output Operate up to 3.6 V, Allowing the Device to be Used in High Voltage Open-Drain Applications
- VREF Goes Down to 0.5 V for Low Voltage CPU Usage
- Partial Power-Down Permitted
- Latch-up Protection Exceed 500 mA per JESD78
- Package Option: TSSOP14
- 40°C to 85°C Operating Temperature Range
- ESD Protection on All Terminals
 - 2000 V HBM, JESD22-A114
 - 1000 V CDM, IEC61000-4-2

2 Applications

- Server
- Base Station
- Wireline Communication

3 Description

The SN74GTL2014 is a 4-channel translator to interface between 3.3-V LVTTTL chip set I/O and Xeon processor GTL–/GTL/GTL+ I/O.

The SN74GTL2014 integrates ESD protection cells on all terminals and is available in a TSSOP package (5.0 mm × 4.4 mm). The device is characterized over the free air temperature range of –40°C to 85°C.

Device Information⁽¹⁾

PART NUMBER	PACKAGE	BODY SIZE (NOM)
SN74GTL2014	TSSOP (14)	5.00 mm × 4.40 mm

(1) For all available packages, see the orderable addendum at the end of the data sheet.

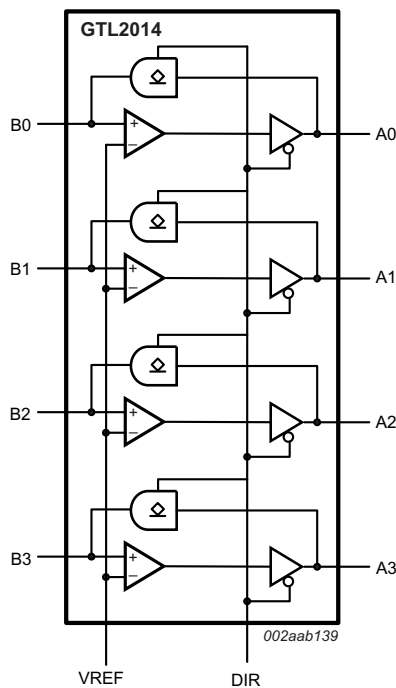

Table of Contents

1 Features	1	8.2 Functional Block Diagram	8
2 Applications	1	8.3 Feature Description	8
3 Description	1	8.4 Device Functional Modes	8
4 Revision History	2	9 Application and Implementation	9
5 Pin Configuration and Functions	3	9.1 Application Information	9
6 Specifications	4	9.2 Typical Application	9
6.1 Absolute Maximum Ratings	4	10 Power Supply Recommendations	12
6.2 Handling Ratings	4	11 Layout	12
6.3 Recommended Operating Conditions	4	11.1 Layout Guidelines	12
6.4 Thermal Information	5	11.2 Layout Example	12
6.5 Electrical Characteristics	5	12 Device and Documentation Support	13
6.6 Dynamic Electrical Characteristics	6	12.1 Trademarks	13
6.7 Typical Characteristics	6	12.2 Electrostatic Discharge Caution	13
7 Parameter Measurement Information	7	12.3 Glossary	13
8 Detailed Description	8	13 Mechanical, Packaging, and Orderable Information	13
8.1 Overview	8		

4 Revision History

Changes from Original (February 2014) to Revision A

Page

• Added Handling Rating table, Feature Description section, Device Functional Modes, Application and Implementation section, Power Supply Recommendations section, Layout section, Device and Documentation Support section, and Mechanical, Packaging, and Orderable Information section.	1
• Updated Specifications section	4
• Updated LVTTTL/TTL to GTL–/GTL/GTL+ application schematic.	9
• Updated LVTTTL/TTL to GTL–/GTL/GTL+ application schematic.	11
• Added <i>Power Supply Recommendations</i>	12

5 Pin Configuration and Functions

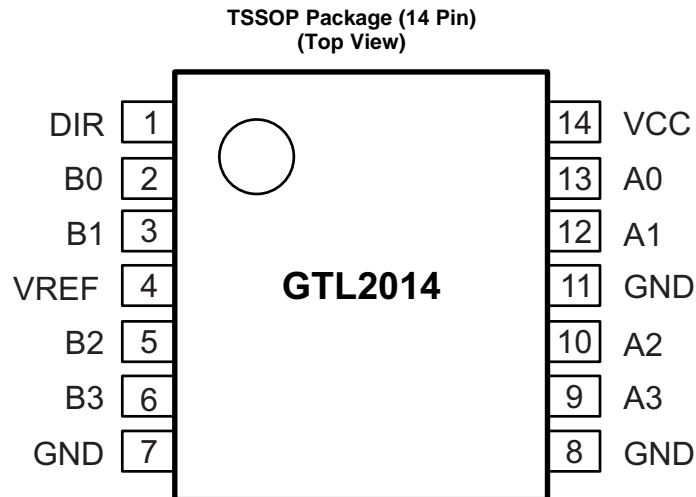

Pin Functions

PIN		DESCRIPTION
NAME	NUMBER	
A0	13	LVTTTL data input/output
A01	12	
A02	10	
A03	9	
B0	2	GTL data input/output
B01	3	
B02	5	
B03	6	
DIR	1	Direction control input (LVTTTL)
GND	7	Ground
	8	
	11	
VCC	14	Supply voltage
VREF	4	GTL reference voltage

6 Specifications

6.1 Absolute Maximum Ratings

 Specified at $T_A = -40^\circ\text{C}$ to 85°C unless otherwise noted⁽¹⁾

			MIN	MAX	UNIT
V_{CC}	Supply voltage		-0.5	4.6	V
I_{IK}	Input clamping current, $V_I < 0$ V			-50	mA
V_{SEL}	Input control voltages SEL ⁽²⁾⁽³⁾		-0.5	6	V
V_I	Input voltage	A port	-0.5	7	V
		B port	-0.5	4.6	
I_{OK}	Control input clamp current, $V_O < 0$ V			-50	mA
V_O	Output voltage	A port	-0.5	7	V
		B port	-0.5	4.6	
I_{OL}	Current into any output in the low state	A port		40	mA
		B port		80	
I_{OH}	Current into any output in the high state			-40	mA

- (1) Stresses beyond those listed under *Absolute Maximum Ratings* may cause permanent damage to the device. These are stress ratings only and functional operation of the device at these conditions is not implied. Exposure to absolute-maximum-rated conditions for extended periods may affect device reliability.
- (2) All voltages are with respect to ground, unless otherwise specified.
- (3) V_I and V_O are used to denote specific conditions for V_{IO} .

6.2 Handling Ratings

			MIN	MAX	UNIT
T_{stg}	Storage temperature range		-55	150	$^\circ\text{C}$
$V_{ESD}^{(1)}$	Human Body Model (HBM), JEDEC: JESD22-A114 ⁽²⁾	All pins	0	2	kV
	IEC61000-4-2 contact discharge ⁽³⁾	All pins	0	1	

- (1) Electrostatic discharge (ESD) to measure device sensitivity/immunity to damage caused by assembly line electrostatic discharges into the device.
- (2) Level listed above is the passing level per ANSI/ESDA/JEDEC JS-001. JEDEC document JEP155 states that 500-V HBM allows safe manufacturing with a standard ESD control process. *Pins listed as 250 V may actually have higher performance.*
- (3) Level listed above is the passing level per EIA-JEDEC JESD22-C101. JEDEC document JEP157 states that 250-V CDM allows safe manufacturing with a standard ESD control process. *Pins listed as 250 V may actually have higher performance.*

6.3 Recommended Operating Conditions

 over operating free-air temperature range (unless otherwise noted)⁽¹⁾

			MIN	NOM	MAX	UNIT
V_{CC}	Supply voltage		3	3.3	3.6	V
V_{TT}	Termination voltage	GTL-	0.85	0.9	0.95	V
		GTL	1.14	1.2	1.26	
		GTL+	1.35	1.5	1.65	
V_{REF}	Reference voltage	Overall	0.5	2 / 3 V_{TT}	$V_{CC} / 2$	V
		GTL-	0.5	0.6	0.63	
		GTL	0.76	0.8	0.84	
		GTL+	0.87	1	1.1	
V_I	Input voltage	A port	0	3.3	5.5 ⁽²⁾	V
		B port	0	V_{TT}	3.6	
V_{IH}	High-level input voltage	A port and DIR	2			V
		B port			$V_{REF} + 50$ mV	

- (1) All unused control inputs of the device must be held at V_{CC} or GND to ensure proper device operation. Refer to the TI application report, *Implications of Slow or Floating CMOS Inputs*, literature number [SCBA004](#).
- (2) The $V_{I(max)}$ of LVTTTL port is 3.6 V if configured as output (DIR=L)

Recommended Operating Conditions (continued)

over operating free-air temperature range (unless otherwise noted)⁽¹⁾

			MIN	NOM	MAX	UNIT
V _{IL}	Low-level input voltage	A port and DIR			0.8	V
		B port		V _{REF} – 50 mV		
I _{OH}	High-level input current	A port			–20	mA
I _{OL}	Low-level output current	A port			20	mA
		B port			50	

6.4 Thermal Information

THERMAL METRIC ⁽¹⁾		SN74GTL2014		UNIT
		PW		
		14 PINS		
R _{θJA}	Junction-to-ambient thermal resistance	136.8		°C/W
R _{θJC(top)}	Junction-to-case (top) thermal resistance	63.0		
R _{θJB}	Junction-to-board thermal resistance	78.6		
ψ _{JT}	Junction-to-top characterization parameter	11.9		
ψ _{JB}	Junction-to-board characterization parameter	77.9		

(1) For more information about traditional and new thermal metrics, see the *IC Package Thermal Metrics* application report, [SPRA953](#).

6.5 Electrical Characteristics

Specified at T_A = –40°C to 85°C (unless otherwise noted)

PARAMETER		TEST CONDITIONS	–40°C TO 85°C			UNIT
			MIN	TYP	MAX	
V _{OH}	A port	V _{CC} = 3 to 3.6 V, I _{OH} = –100 μA	V _{CC} – 0.2			V
		V _{CC} = 3 V, I _{OH} = –16 mA	2			
V _{OL}	A port	V _{CC} = 3 V, I _{OL} = 8 mA	0.28	0.4	V	
	A port	V _{CC} = 3 V, I _{OL} = 16 mA	0.55	0.8		
	B port	V _{CC} = 3 V, I _{OL} = 40 mA	0.23	0.4		
I _I	A port	V _{CC} = 3.6 V, V _I = V _{CC}			±1	μA
		V _{CC} = 3.6 V, V _I = 0 V			±1	
		V _{CC} = 3.6 V, V _I = 5.5 V			5	
	B port	V _{CC} = 3.6 V, V _I = V _{TT} or GND			±1	
	Control pin	V _{CC} = 3.6 V, V _I = V _{CC} or 0 V			±1	μA
I _{off}	OFF-state output current on A port	V _{CC} = 0 V, V _{IO} = 0 to 3.6 V			±10	μA
	OFF-state output current on A port	V _{CC} = 0 V, V _{IO} = 3.6 to 5.5 V			±100	
	OFF-state output current on B port	V _{CC} = 0 V, V _{IO} = 0 to 3.6 V			±10	
I _{CC}	A port	V _{CC} = 3.6 V, V _I = V _{CC} or GND, I _O = 0	3	10	mA	
	B port	V _{CC} = 3.6 V, V _I = V _{TT} or GND, I _O = 0	3	10	mA	
ΔI _{CC}	A port or control input	V _{CC} = 3.6 V, V _I = V _{CC} – 0.6 V			500	μA
C _I	Input capacitance of control pin	V _I = 3.0 V or 0 V	2	2.5	pF	
C _{IO}	A port	V _O = 3 V or 0	4	6	pF	
	B port	V _O = V _{TT} or 0	5.46	5.55		

6.6 Dynamic Electrical Characteristics

over operating range, $T_A = -40^{\circ}\text{C}$ to 85°C , $V_{CC} = 1.65$ to 4.6 V, $\text{GND} = 0$ V for GTL (see *Functional Block Diagram*)

PARAMETER		GTL-			GTL			GTL+			UNIT
		$V_{CC} = 3.3 \text{ V} \pm 0.3 \text{ V}$ $V_{REF} = 0.6 \text{ V}$ $V_{TT} = 0.9 \text{ V}$			$V_{CC} = 3.3 \text{ V} \pm 0.3 \text{ V}$ $V_{REF} = 0.8 \text{ V}$ $V_{TT} = 1.2 \text{ V}$			$V_{CC} = 3.3 \text{ V} \pm 0.3 \text{ V}$ $V_{REF} = 1 \text{ V}$ $V_{TT} = 1.5 \text{ V}$			
		MIN	TYP	MAX	MIN	TYP	MAX	MIN	TYP	MAX	
t_{PLH} (low to high propagation delay)	An to Bn	2.8			2.8			2.8			ns
t_{PHL} (high to low propagation delay)		3.3			3.4			3.4			
t_{PLH} (low to high propagation delay)	Bn to An	5.3			5.2			5.1			ns
t_{PHL} (high to low propagation delay)		5.2			4.9			4.7			

6.7 Typical Characteristics

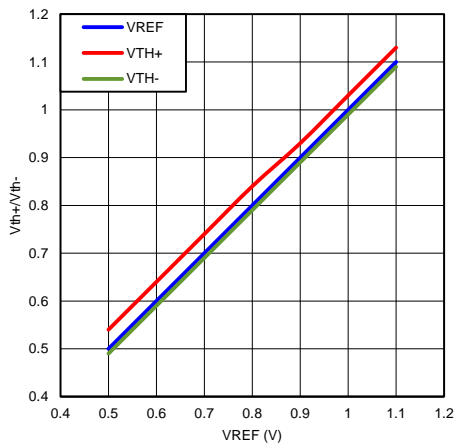

Figure 1. GTL Vth+ and Vth- vs VREF (25°C)

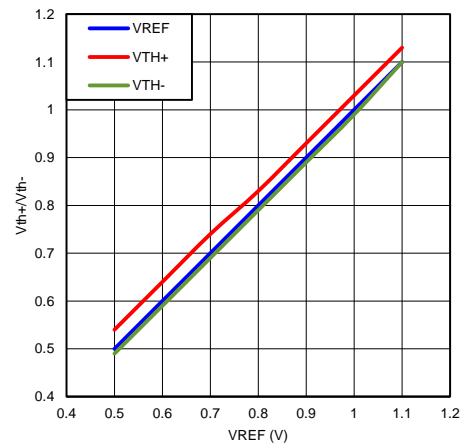

Figure 2. GTL Vth+ and Vth- vs VREF (-40°C)

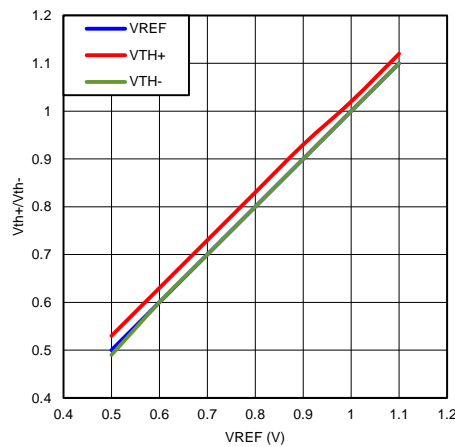
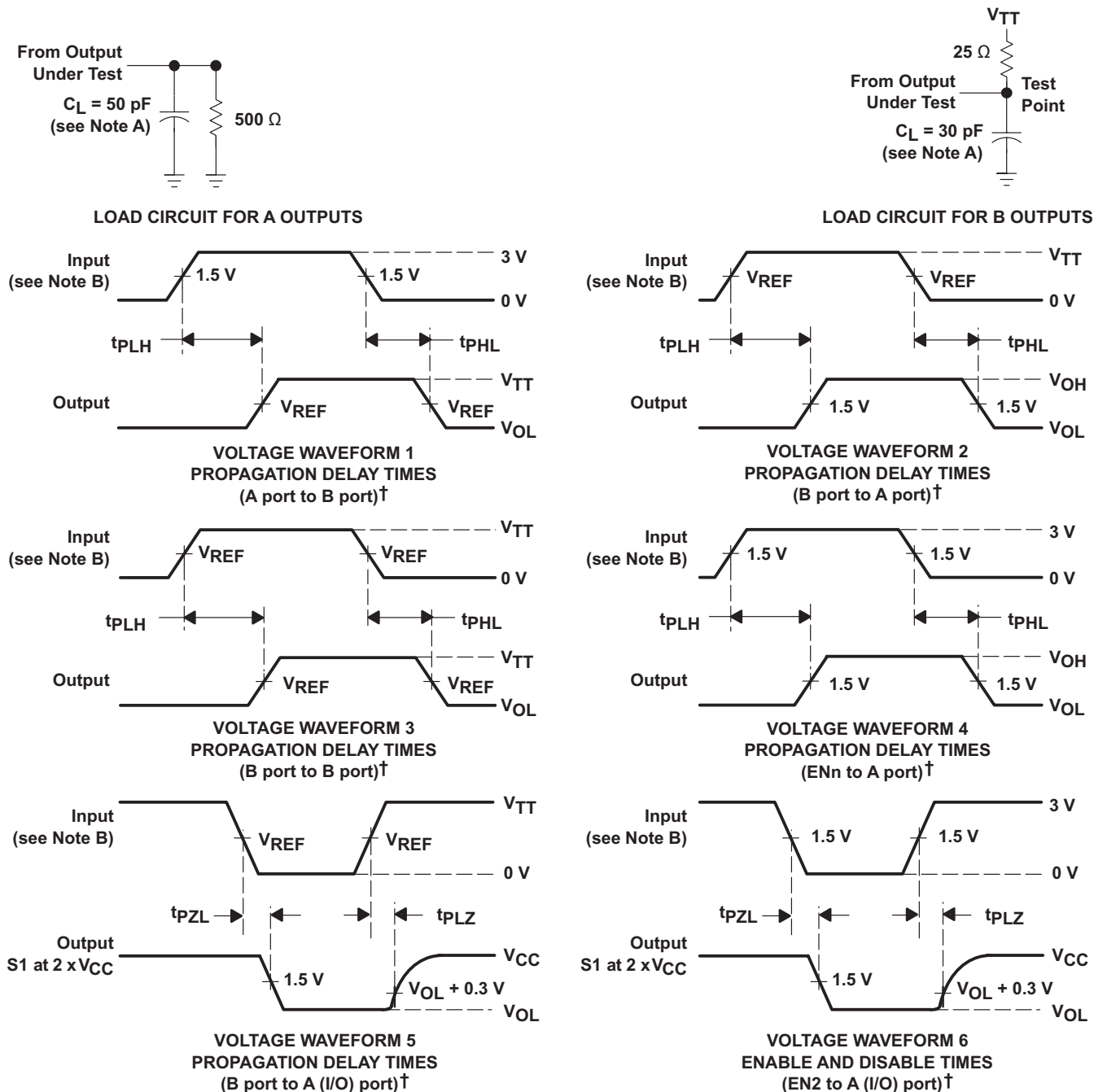

Figure 3. GTL Vth+ and Vth- vs VREF (125°C)

7 Parameter Measurement Information

$V_{TT} = 1.2\text{ V}$, $V_{REF} = 0.8\text{ V}$ for GTL and $V_{TT} = 1.5\text{ V}$, $V_{REF} = 1\text{ V}$ FOR GTL+



† All control inputs are LVTTTL levels.

NOTES: A. C_L includes probe and jig capacitance.

B. All input pulses are supplied by generators having the following characteristics: $PRR \leq 10\text{ MHz}$, $Z_O = 50\ \Omega$, $t_r \leq 2.5\text{ ns}$, $t_f \leq 2.5\text{ ns}$.

C. The outputs are measured one at a time, with one transition per measurement.

Figure 4. Load Circuits and Voltage Waveforms

8 Detailed Description

8.1 Overview

The GTL2014 is a 4-channel translating transceiver designed for 3.3-V LVTTTL system interface with a GTL–/GTL/GTL+ bus, where GTL–/GTL/GTL+ refers to the reference voltage of the GTL bus and the input/output voltage thresholds associated with it.

The direction pin allows the part to function as either a GTL-to-LVTTTL sampling receiver or as a LVTTTL-to-GTL interface.

8.2 Functional Block Diagram

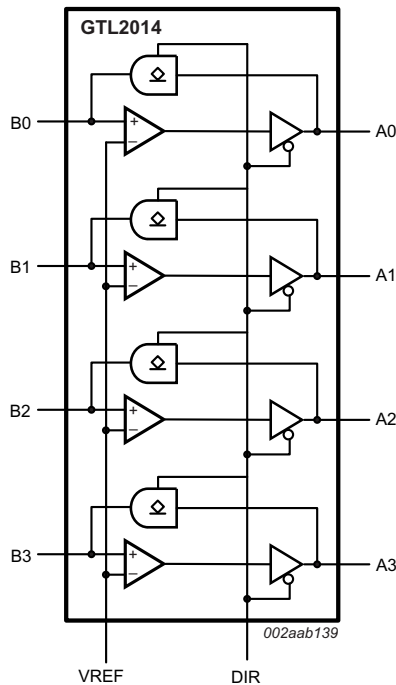

8.3 Feature Description

8.3.1 5 V tolerance on LVTTTL input

The GTL2014 LVTTTL inputs (only) are tolerant up to 5.5 V and allows direct access to TTL or 5 V CMOS inputs. The LVTTTL outputs are not 5.5 V tolerant.

8.3.2 3.6 V tolerance on GTL Input/Output

The GTL2014 GTL inputs and outputs operate up to 3.6 V, allowing the device to be used in higher voltage open-drain output applications.

8.3.3 Ultra-Low VREF and High Bandwidth

GTL2014's VREF tracks down to 0.5 V for low voltage CPUs with excellent propagation delay performance. This feature allows the GTL2014 to support high data rates with the GTL– bus.

8.4 Device Functional Modes

The GTL2014 performs translation in two directions. One direction is GTL–/GTL/GTL+ to LVTTTL when DIR is tied to GND. With appropriate VREF set up, the GTL input can be compliant with GTL–/GTL/GTL+. Another direction is LVTTTL to GTL–/GTL/GTL+ when DIR is tied to VCC. 3.6 V tolerance on the GTL output allows the GTL outputs to pull up to any voltage level under 3.6 V.

9 Application and Implementation

NOTE

Information in the following applications sections is not part of the TI component specification, and TI does not warrant its accuracy or completeness. TI's customers are responsible for determining suitability of components for their purposes. Customers should validate and test their design implementation to confirm system functionality.

9.1 Application Information

GTL2014 is the voltage translator for GTL–/GTL/GTL+ to LVTTTL or LVTTTL to GTL–/GTL/GTL+. Please find the reference schematic and recommend value for passive component in the [Typical Application](#).

9.2 Typical Application

9.2.1 GTL–/GTL/GTL+ to LVTTTL

Select appropriate VTT/VREF based upon GTL–/GTL/GTL+. The parameters in [Recommended Operating Conditions](#) are compliant to the GTL specification.

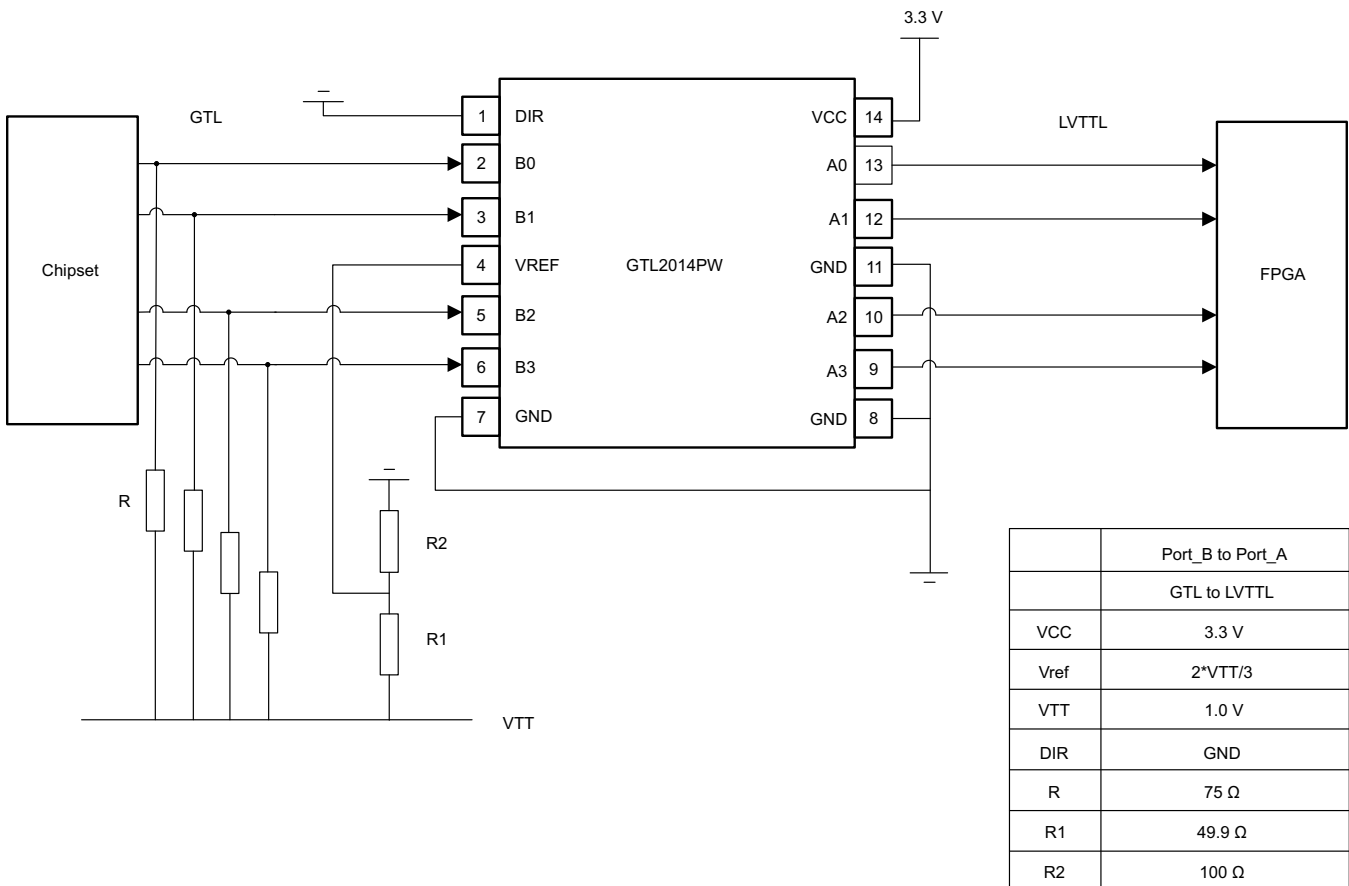

Figure 5. Application Diagram for GTL to LVTTTL

Typical Application (continued)

9.2.1.1 Design Requirements

The GTL2014 requires industrial standard LVTTTL and GTL inputs. The design example in [Application Information](#) show standard voltage level and typical resistor values.

NOTE

Only LVTTTL terminals (A1/A2/A3/A4) are tolerant to 5 V.

9.2.1.2 Detailed Design Procedure

To begin the design process, determine the following:

1. Select direction base upon application (GTL–/GTL/GTL+ to LVTTTL or LVTTTL to GTL–/GTL/GTL+).
2. Set up appropriate DIR pin and VREF/VTT.
3. Choose correct pullup resistor value base upon data rate and driving current requirement (for LVTTTL to GTL–/GTL/GTL+).

9.2.1.3 Application Curve

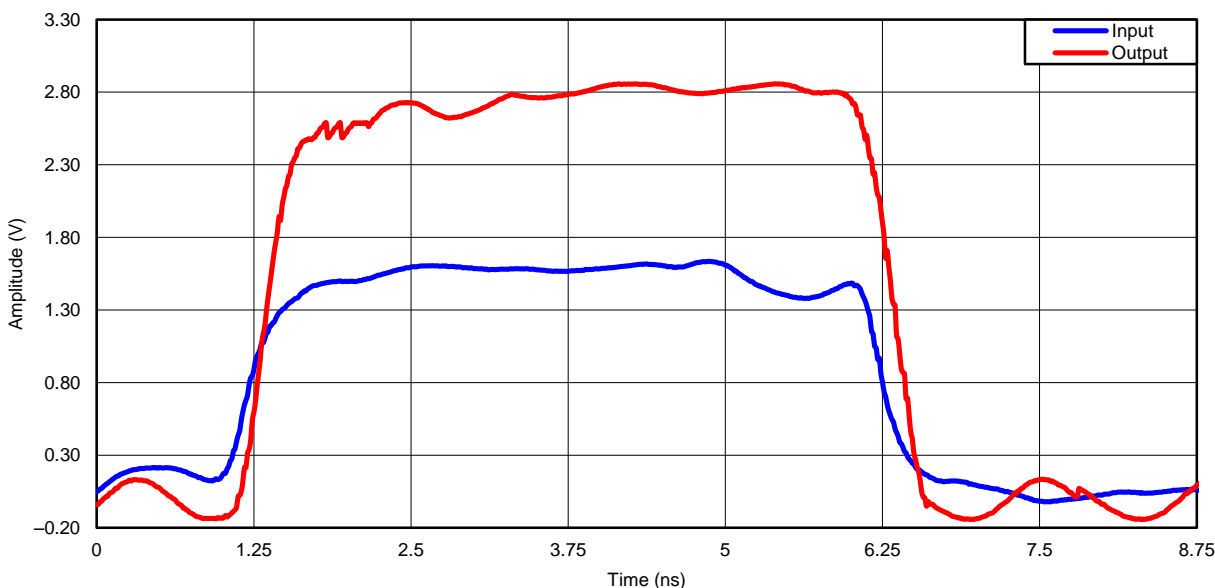

Figure 6. GTL-to-LVTTTL, VREF = 1 V, VIN = 1.5 V, 100 MHz

Typical Application (continued)

9.2.2 LVTTTL/TTL to GTL-/GTL/GTL+

Because GTL is an open-drain interface, the selection of pullup resistor depends on the application requirement (for example, data rate) and PCB trace capacitance.

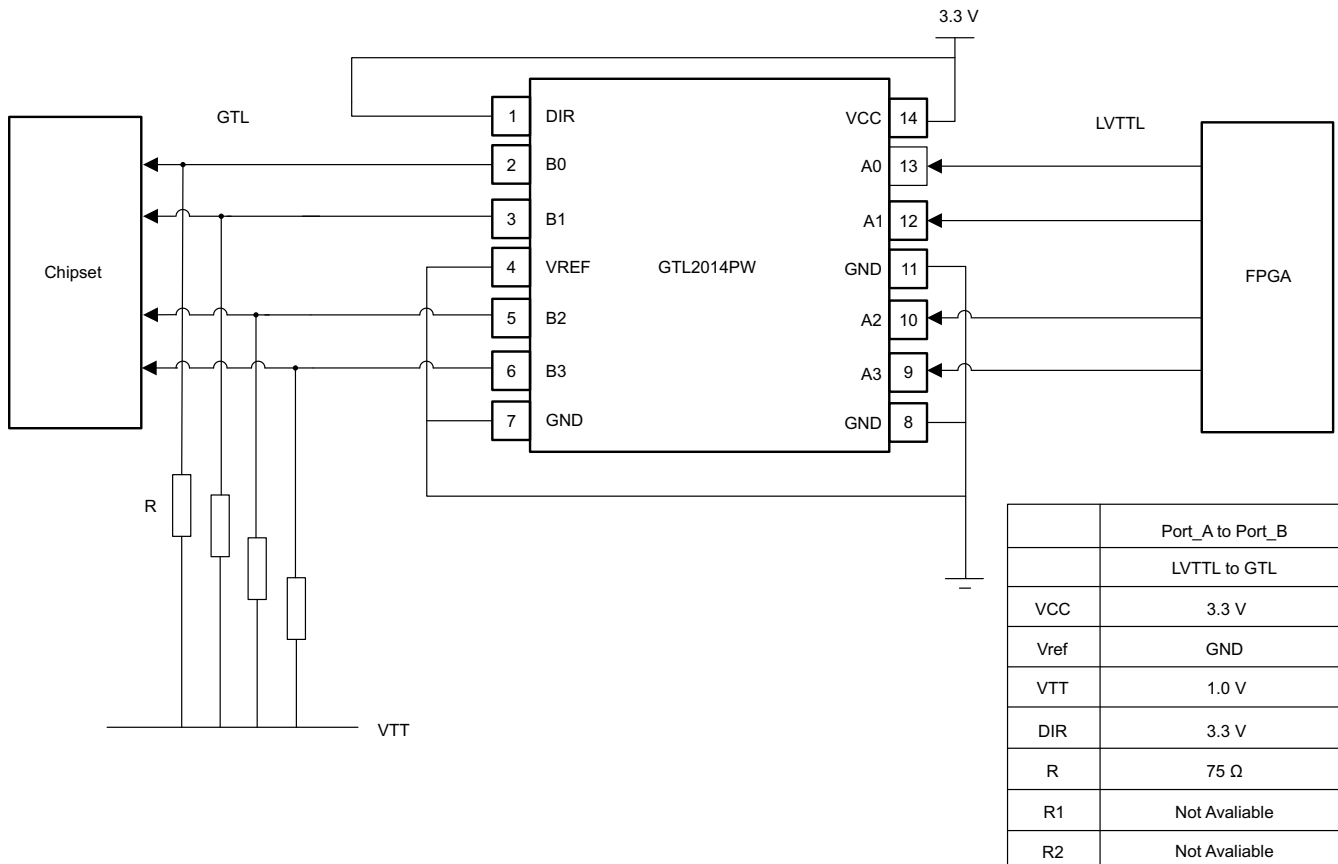

Figure 7. Application Diagram for LVTTTL to GTL

9.2.2.1 Design Requirements

The GTL2014 requires industrial standard LVTTTL and GTL inputs. The design example in the [Application Information](#) section show standard voltage level and typical resistor values.

NOTE

Only LVTTTL terminals (A1/A2/A3/A4) are tolerant to 5 V.

9.2.2.2 Detailed Design Procedure

To begin the design process, determine the following:

1. Select direction based upon application (GTL-/GTL/GTL+ to LVTTTL or LVTTTL to GTL-/GTL/GTL+).
2. Set up appropriate DIR pin and VREF/VTT.
3. Choose correct pullup resistor value base upon data rate and driving current requirement (for LVTTTL to GTL-/GTL/GTL+).

Typical Application (continued)

9.2.2.3 Application Curve

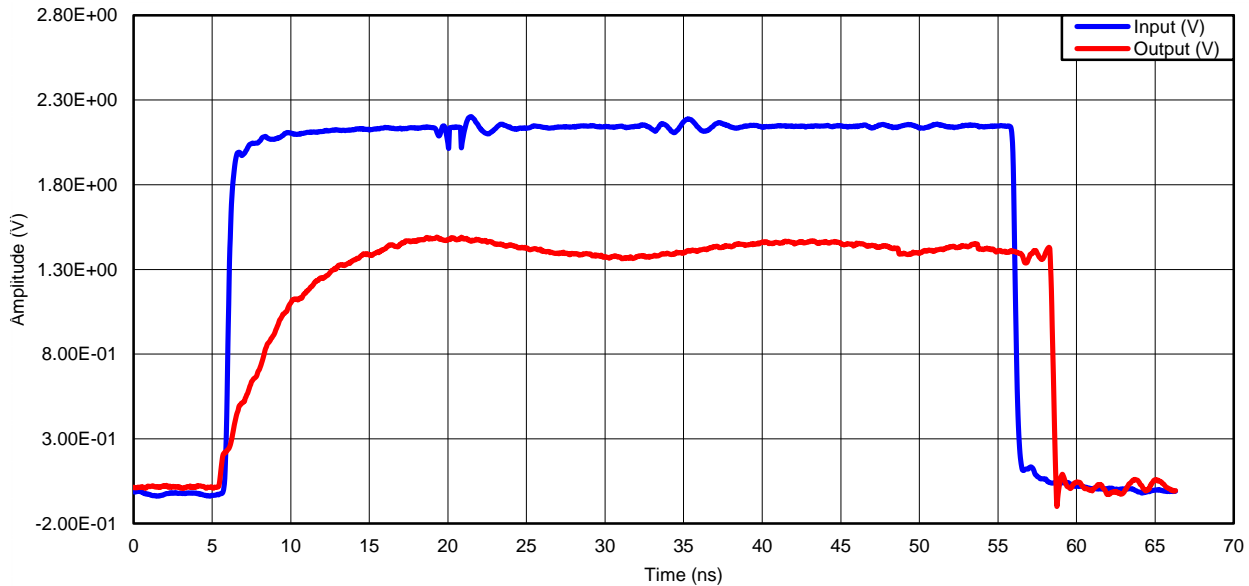

Figure 8. LVTTTL-to-GTL, VREF = 1 V, VTT = 1.5 V, 10 MHz

10 Power Supply Recommendations

Because GTL is a low voltage interface, TI recommends a 0.1- μ F decoupling capacitor for VREF.

11 Layout

11.1 Layout Guidelines

Typically, GTL/LVTTTL is running at a low data rate; however, the GTL2014 is optimized for excellent propagation delay, slew rate, bandwidth, and is able support 100-MHz frequencies.

11.2 Layout Example

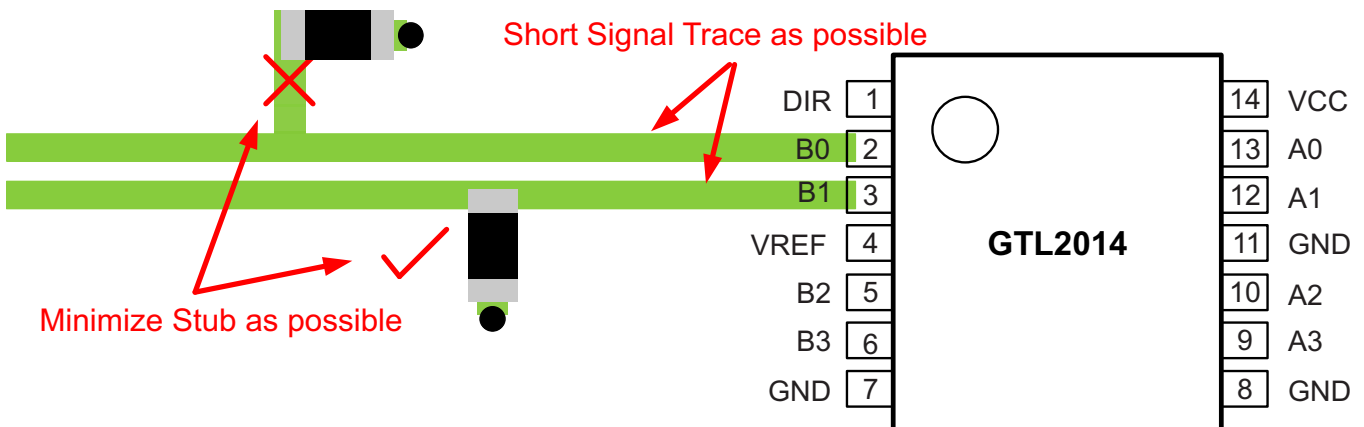

Figure 9. Layout Example for GTL Trace

12 Device and Documentation Support

12.1 Trademarks

All trademarks are the property of their respective owners.

12.2 Electrostatic Discharge Caution



This integrated circuit can be damaged by ESD. Texas Instruments recommends that all integrated circuits be handled with appropriate precautions. Failure to observe proper handling and installation procedures can cause damage.

ESD damage can range from subtle performance degradation to complete device failure. Precision integrated circuits may be more susceptible to damage because very small parametric changes could cause the device not to meet its published specifications.

12.3 Glossary

[SLYZ022](#) — *TI Glossary*.

This glossary lists and explains terms, acronyms, and definitions.

13 Mechanical, Packaging, and Orderable Information

The following pages include mechanical, packaging, and orderable information. This information is the most current data available for the designated devices. This data is subject to change without notice and revision of this document. For browser-based versions of this data sheet, refer to the left-hand navigation.

PACKAGING INFORMATION

Orderable Device	Status (1)	Package Type	Package Drawing	Pins	Package Qty	Eco Plan (2)	Lead/Ball Finish (6)	MSL Peak Temp (3)	Op Temp (°C)	Device Marking (4/5)	Samples
SN74GTL2014PWR	ACTIVE	TSSOP	PW	14	2000	Green (RoHS & no Sb/Br)	CU NIPDAU CU SN	Level-1-260C-UNLIM	-40 to 85	GT14	Samples

(1) The marketing status values are defined as follows:

ACTIVE: Product device recommended for new designs.

LIFEBUY: TI has announced that the device will be discontinued, and a lifetime-buy period is in effect.

NRND: Not recommended for new designs. Device is in production to support existing customers, but TI does not recommend using this part in a new design.

PREVIEW: Device has been announced but is not in production. Samples may or may not be available.

OBSOLETE: TI has discontinued the production of the device.

(2) Eco Plan - The planned eco-friendly classification: Pb-Free (RoHS), Pb-Free (RoHS Exempt), or Green (RoHS & no Sb/Br) - please check <http://www.ti.com/productcontent> for the latest availability information and additional product content details.

TBD: The Pb-Free/Green conversion plan has not been defined.

Pb-Free (RoHS): TI's terms "Lead-Free" or "Pb-Free" mean semiconductor products that are compatible with the current RoHS requirements for all 6 substances, including the requirement that lead not exceed 0.1% by weight in homogeneous materials. Where designed to be soldered at high temperatures, TI Pb-Free products are suitable for use in specified lead-free processes.

Pb-Free (RoHS Exempt): This component has a RoHS exemption for either 1) lead-based flip-chip solder bumps used between the die and package, or 2) lead-based die adhesive used between the die and leadframe. The component is otherwise considered Pb-Free (RoHS compatible) as defined above.

Green (RoHS & no Sb/Br): TI defines "Green" to mean Pb-Free (RoHS compatible), and free of Bromine (Br) and Antimony (Sb) based flame retardants (Br or Sb do not exceed 0.1% by weight in homogeneous material)

(3) MSL, Peak Temp. - The Moisture Sensitivity Level rating according to the JEDEC industry standard classifications, and peak solder temperature.

(4) There may be additional marking, which relates to the logo, the lot trace code information, or the environmental category on the device.

(5) Multiple Device Markings will be inside parentheses. Only one Device Marking contained in parentheses and separated by a "-" will appear on a device. If a line is indented then it is a continuation of the previous line and the two combined represent the entire Device Marking for that device.

(6) Lead/Ball Finish - Orderable Devices may have multiple material finish options. Finish options are separated by a vertical ruled line. Lead/Ball Finish values may wrap to two lines if the finish value exceeds the maximum column width.

Important Information and Disclaimer: The information provided on this page represents TI's knowledge and belief as of the date that it is provided. TI bases its knowledge and belief on information provided by third parties, and makes no representation or warranty as to the accuracy of such information. Efforts are underway to better integrate information from third parties. TI has taken and continues to take reasonable steps to provide representative and accurate information but may not have conducted destructive testing or chemical analysis on incoming materials and chemicals. TI and TI suppliers consider certain information to be proprietary, and thus CAS numbers and other limited information may not be available for release.

In no event shall TI's liability arising out of such information exceed the total purchase price of the TI part(s) at issue in this document sold by TI to Customer on an annual basis.

TAPE AND REEL INFORMATION



QUADRANT ASSIGNMENTS FOR PIN 1 ORIENTATION IN TAPE



*All dimensions are nominal

Device	Package Type	Package Drawing	Pins	SPQ	Reel Diameter (mm)	Reel Width W1 (mm)	A0 (mm)	B0 (mm)	K0 (mm)	P1 (mm)	W (mm)	Pin1 Quadrant
SN74GTL2014PWR	TSSOP	PW	14	2000	330.0	12.4	6.9	5.6	1.6	8.0	12.0	Q1
SN74GTL2014PWR	TSSOP	PW	14	2000	330.0	12.4	6.9	5.6	1.6	8.0	12.0	Q1

TAPE AND REEL BOX DIMENSIONS

*All dimensions are nominal

Device	Package Type	Package Drawing	Pins	SPQ	Length (mm)	Width (mm)	Height (mm)
SN74GTL2014PWR	TSSOP	PW	14	2000	367.0	367.0	35.0
SN74GTL2014PWR	TSSOP	PW	14	2000	364.0	364.0	27.0

PW (R-PDSO-G14)

PLASTIC SMALL OUTLINE

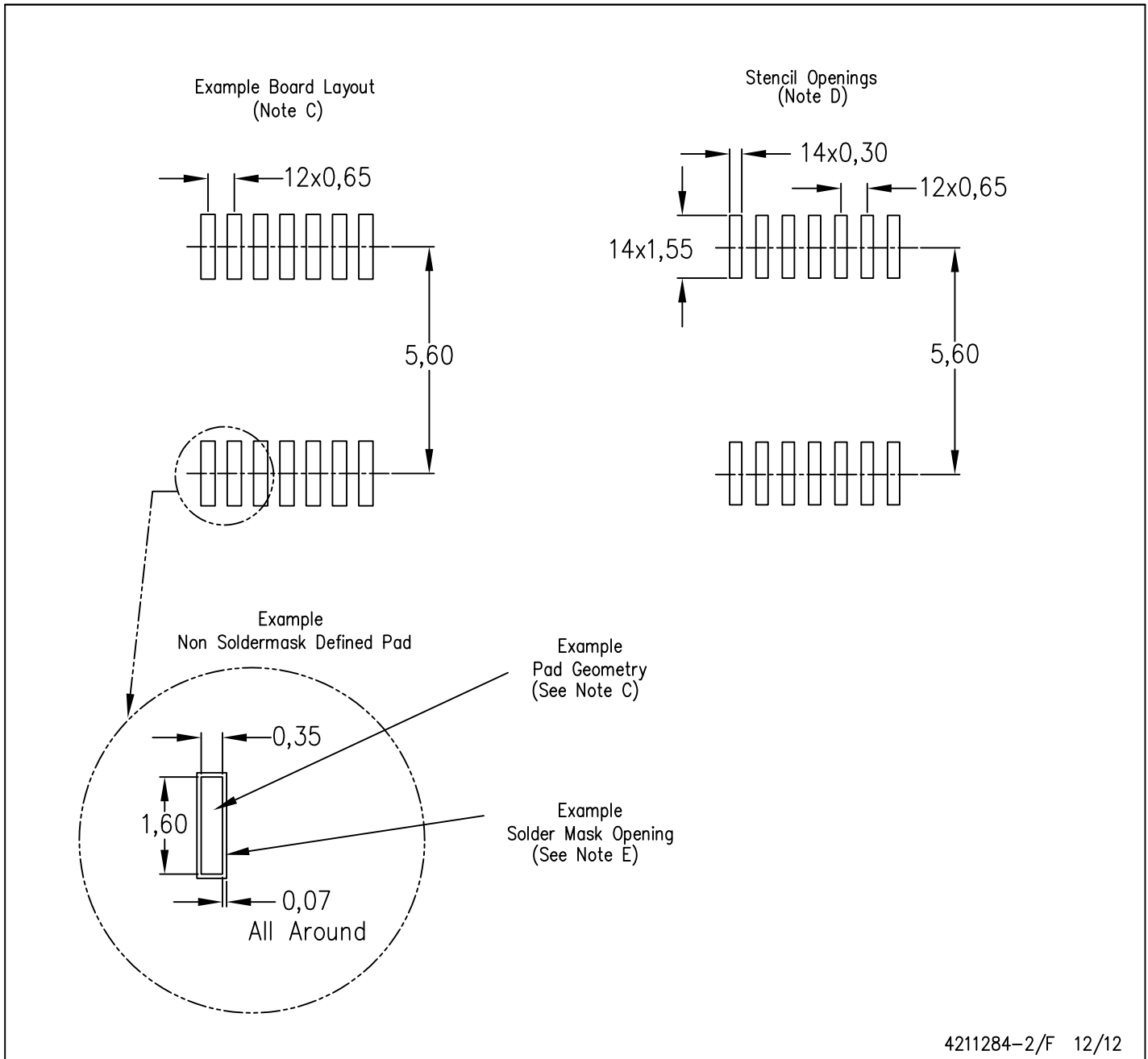

- NOTES:
- All linear dimensions are in millimeters.
 - This drawing is subject to change without notice.
 - Publication IPC-7351 is recommended for alternate designs.
 - Laser cutting apertures with trapezoidal walls and also rounding corners will offer better paste release. Customers should contact their board assembly site for stencil design recommendations. Refer to IPC-7525 for other stencil recommendations.
 - Customers should contact their board fabrication site for solder mask tolerances between and around signal pads.

IMPORTANT NOTICE

Texas Instruments Incorporated and its subsidiaries (TI) reserve the right to make corrections, enhancements, improvements and other changes to its semiconductor products and services per JESD46, latest issue, and to discontinue any product or service per JESD48, latest issue. Buyers should obtain the latest relevant information before placing orders and should verify that such information is current and complete. All semiconductor products (also referred to herein as "components") are sold subject to TI's terms and conditions of sale supplied at the time of order acknowledgment.

TI warrants performance of its components to the specifications applicable at the time of sale, in accordance with the warranty in TI's terms and conditions of sale of semiconductor products. Testing and other quality control techniques are used to the extent TI deems necessary to support this warranty. Except where mandated by applicable law, testing of all parameters of each component is not necessarily performed.

TI assumes no liability for applications assistance or the design of Buyers' products. Buyers are responsible for their products and applications using TI components. To minimize the risks associated with Buyers' products and applications, Buyers should provide adequate design and operating safeguards.

TI does not warrant or represent that any license, either express or implied, is granted under any patent right, copyright, mask work right, or other intellectual property right relating to any combination, machine, or process in which TI components or services are used. Information published by TI regarding third-party products or services does not constitute a license to use such products or services or a warranty or endorsement thereof. Use of such information may require a license from a third party under the patents or other intellectual property of the third party, or a license from TI under the patents or other intellectual property of TI.

Reproduction of significant portions of TI information in TI data books or data sheets is permissible only if reproduction is without alteration and is accompanied by all associated warranties, conditions, limitations, and notices. TI is not responsible or liable for such altered documentation. Information of third parties may be subject to additional restrictions.

Resale of TI components or services with statements different from or beyond the parameters stated by TI for that component or service voids all express and any implied warranties for the associated TI component or service and is an unfair and deceptive business practice. TI is not responsible or liable for any such statements.

Buyer acknowledges and agrees that it is solely responsible for compliance with all legal, regulatory and safety-related requirements concerning its products, and any use of TI components in its applications, notwithstanding any applications-related information or support that may be provided by TI. Buyer represents and agrees that it has all the necessary expertise to create and implement safeguards which anticipate dangerous consequences of failures, monitor failures and their consequences, lessen the likelihood of failures that might cause harm and take appropriate remedial actions. Buyer will fully indemnify TI and its representatives against any damages arising out of the use of any TI components in safety-critical applications.

In some cases, TI components may be promoted specifically to facilitate safety-related applications. With such components, TI's goal is to help enable customers to design and create their own end-product solutions that meet applicable functional safety standards and requirements. Nonetheless, such components are subject to these terms.

No TI components are authorized for use in FDA Class III (or similar life-critical medical equipment) unless authorized officers of the parties have executed a special agreement specifically governing such use.

Only those TI components which TI has specifically designated as military grade or "enhanced plastic" are designed and intended for use in military/aerospace applications or environments. Buyer acknowledges and agrees that any military or aerospace use of TI components which have **not** been so designated is solely at the Buyer's risk, and that Buyer is solely responsible for compliance with all legal and regulatory requirements in connection with such use.

TI has specifically designated certain components as meeting ISO/TS16949 requirements, mainly for automotive use. In any case of use of non-designated products, TI will not be responsible for any failure to meet ISO/TS16949.

Products

Audio	www.ti.com/audio
Amplifiers	amplifier.ti.com
Data Converters	dataconverter.ti.com
DLP® Products	www.dlp.com
DSP	dsp.ti.com
Clocks and Timers	www.ti.com/clocks
Interface	interface.ti.com
Logic	logic.ti.com
Power Mgmt	power.ti.com
Microcontrollers	microcontroller.ti.com
RFID	www.ti-rfid.com
OMAP Applications Processors	www.ti.com/omap
Wireless Connectivity	www.ti.com/wirelessconnectivity

Applications

Automotive and Transportation	www.ti.com/automotive
Communications and Telecom	www.ti.com/communications
Computers and Peripherals	www.ti.com/computers
Consumer Electronics	www.ti.com/consumer-apps
Energy and Lighting	www.ti.com/energy
Industrial	www.ti.com/industrial
Medical	www.ti.com/medical
Security	www.ti.com/security
Space, Avionics and Defense	www.ti.com/space-avionics-defense
Video and Imaging	www.ti.com/video

TI E2E Community

e2e.ti.com